



DESIGN NOTES

The LTC1446/LTC1446L: World's First Dual 12-Bit DACs in SO-8

Design Note 131

Hassan Malik and Kevin R. Hoskins

The LTC[®]1446/LTC1446L are the first dual, single supply, rail-to-rail voltage output 12-bit DACs. Both parts include an internal reference and two DACs with rail-to-rail output buffer amplifiers, packaged into a space-saving 8-pin SO or PDIP package. The LTC1446's patented architecture is inherently monotonic and has excellent 12-bit DNL, guaranteed to be less than 0.5LSB. These parts have an easy-to-use SPI compatible interface that allows daisy-chaining.

Low Power 5V or 3V Single Supply

The LTC1446 has an output swing of 0V to 4.095V, with each LSB equal to 1mV. It operates from a single 4.5V to 5.5V supply, drawing 1mA. The LTC1446L has an output swing of 0V to 2.5V, operates on a single 2.7V to 5.5V supply and draws 650 μ A.

Complete Stand-Alone Performance

Figure 1 shows a block diagram of the LTC1446/LTC1446L. The data inputs for both DAC A and DAC B are clocked into one 24-bit shift register. The first 12-bit segment is for

DAC A and the second is for DAC B. Each 12-bit segment is loaded MSB first and latched into the shift register on the rising edge of the clock. When all the data has been shifted in, it is loaded into the DAC registers when the signal on the \overline{CS}/LD pin changes to a logic high. This updates both 12-bit DACs and internally disables the CLK signal. The D_{OUT} pin allows the user to daisy-chain several DACs together. Power-on reset initializes the outputs to zero scale.

Rail-to-Rail Outputs

The on-chip output buffer amplifiers can source or sink over 5mA with a 5V supply. More over, they have true rail-to-rail performance. This results in excellent load regulation up to the 4.095V full-scale output with a 4.5V supply. When sinking current with outputs close to zero scale, the effective output impedance is about 50 Ω . The midscale glitch on the output is 20nV \cdot s and the digital feedthrough is a negligible 0.15nV \cdot s.

 LTC and LT are registered trademarks of Linear Technology Corporation.

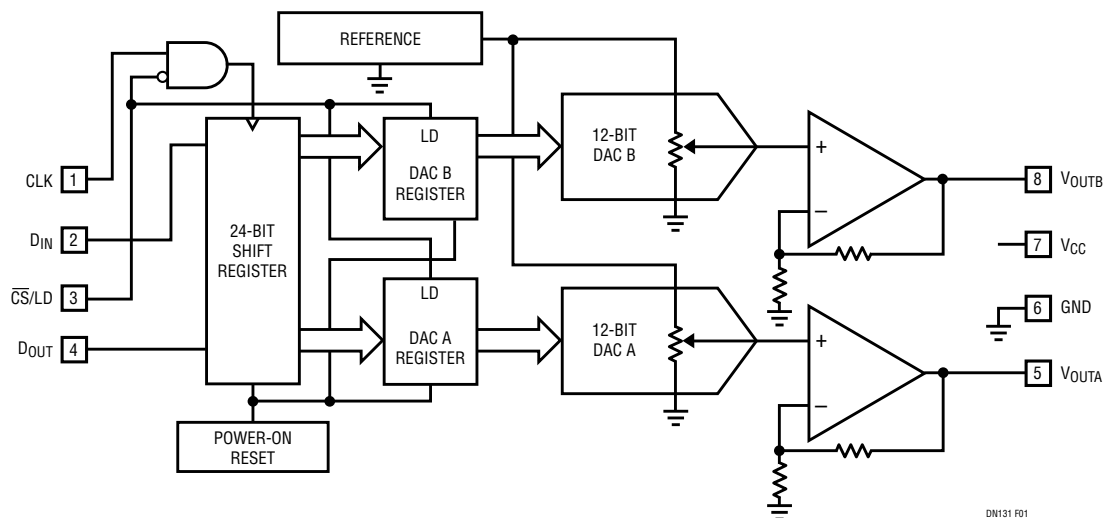

Figure 1. Dual 12-Bit Rail-to-Rail Performance in an SO-8 Package

A Wide Range of Applications

Some of the typical applications for these parts include digital calibration, industrial process control, automatic test equipment, cellular telephones and portable battery-powered applications. Figure 2 shows how easy these parts are to use.

Figure 3 shows how to use one LTC1446 to make an autoranging ADC. The microprocessor adjusts the ADC's reference span and offset by loading the appropriate digital code into the LTC1446. V_{OUTA} controls the common pin for the analog inputs to the LTC1296 and V_{OUTB} controls the reference span by setting the LTC1296's REF^+ pin. The LTC1296 has a Shutdown pin whose output is a logic low in shutdown mode. During shutdown, this logic low turns off the PNP transistor that supplies power to the LTC1446. The resistors and capacitors lowpass filter the LTC1446 outputs, attenuating noise.

Figure 4 shows how to use an LTC1446 and an LT[®]1077 to make a wide bipolar output swing 12-bit DAC with a digitally programmable offset. The voltage on DAC A's

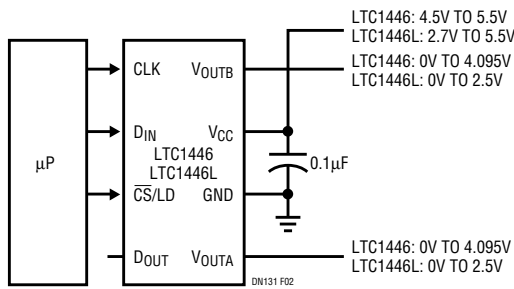

Figure 2. Easy Stand-Alone Application for the LTC1446 or LTC1446L

output (V_{OUTA}) is used as the offset voltage. Figure 4 also shows how the circuit's output voltage changes as a function of the input digital code.

Conclusion

The LTC1446/LTC1446L are the world's only DACs that offer dual 12-bit stand-alone performance in an 8-pin SO or PDIP package. Along with their amazing density, these DACs do not compromise performance, offering excellent 12-bit DNL, rail-to-rail voltage outputs and very low power dissipation. This allows users to save circuit board space without sacrificing performance.

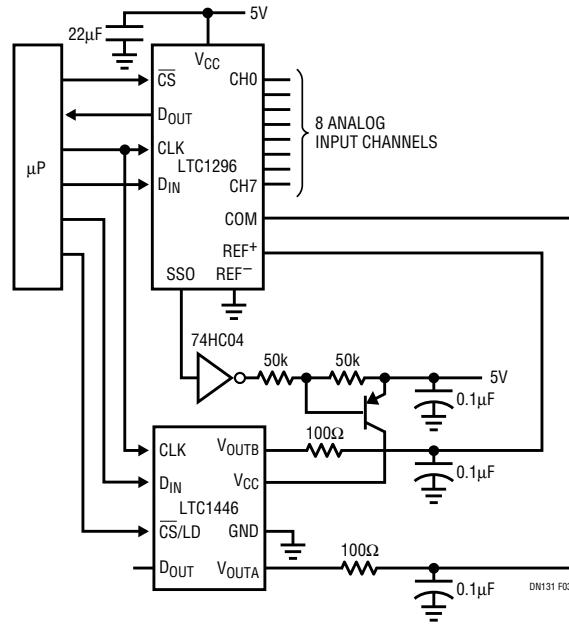

Figure 3. An Autoranging 8-Channel ADC with Shutdown

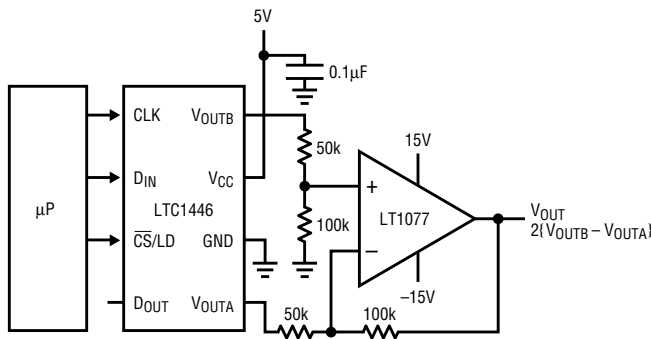
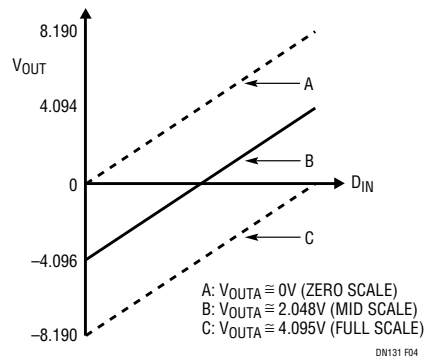

Figure 4. A Wide-Swing, Bipolar Output DAC with Digitally Controlled Offset



For literature on our Digital-to-Analog Converters, call **1-800-4-LINEAR**. For applications help, call (408) 432-1900, Ext. 2525